



# WOOD LATHE MODEL G1067Z INSTRUCTION MANUAL



COPYRIGHT © 1996 BY GRIZZLY INDUSTRIAL, INC.  
WARNING: NO PORTION OF THIS MANUAL MAY BE REPRODUCED IN ANY SHAPE  
OR FORM WITHOUT THE WRITTEN APPROVAL OF GRIZZLY INDUSTRIAL, INC.  
REVISED FEBRUARY, 1999. PRINTED IN U.S.A.

# Table Of Contents

	<b>PAGE</b>
<b>1. INTRODUCTION</b> .....	2
SAFETY RULES FOR ALL TOOLS .....	3
UNPACKING.....	4
PIECE INVENTORY .....	4
CLEAN UP .....	5
SITE CONSIDERATIONS .....	5
CIRCUIT REQUIREMENTS .....	6
<b>2. ASSEMBLY</b> .....	7
PRE-ASSEMBLY .....	7
STAND.....	7-8
INSTALLING THE SWITCH .....	9
TOOL REST .....	10
TAILSTOCK .....	10
SPUR CENTER .....	11
FACE PLATE .....	11
<b>3. ADJUSTMENTS</b> .....	12
HEADSTOCK .....	12-13
TAILSTOCK .....	13
LIVE CENTER .....	14
SPEED SELECTOR .....	14
<b>4. OPERATIONS</b> .....	15
LATHE SAFETY RULES .....	15
TEST RUN .....	16
TOOL REST .....	16
SPINDLE TURNING .....	17
OUTBOARD TURNING .....	18
INDEXING.....	18
<b>5. MAINTENANCE</b> .....	19
GENERAL.....	19
LUBRICATION .....	19
BED.....	19
<b>6. CLOSURE</b> .....	20
MACHINE DATA.....	21
PART BREAKDOWN .....	22-23
PART LISTS .....	24
WARRANTY AND RETURNS .....	27

# SECTION 1: INTRODUCTION

---

Grizzly Industrial, Inc. is proud to offer the Model G1067Z Wood Lathe. This lathe is a part of Grizzly's growing family of fine woodworking machinery. When used according to the guidelines stated in this manual, you can expect years of trouble-free, enjoyable operation.

The Model G1067Z is intended for home and medium-duty professional use. This lathe features a 1,725 R.P.M., 1 H.P. capacitor-start motor, mechanical ON/OFF switch and rotating head for spindle turning and bowl turning.

All running parts utilize shielded ball bearings, which require no lubrication for the life of the bearings.

We are also pleased to provide this manual with the Model G1067Z. It was written to guide you through assembly, review safety considerations, and cover general operating procedures. It represents our latest effort to produce the best documentation possible. If you have any criticisms that you feel we should pay attention to in our next printing, please write to us at the Bellingham, WA address at the end of this section.

Most importantly, we stand behind our machines. We have excellent regional service departments at your disposal should the need arise. If you have any service questions or parts requests, please call or write to us at the location listed below.

Grizzly Industrial, Inc.  
1203 Lycoming Mall Circle  
Muncy, PA 17756  
Phone: (570) 546-9663  
Fax: (800) 438-5901  
E-Mail: [techsupport@grizzly.com](mailto:techsupport@grizzly.com)  
Web Site: <http://www.grizzly.com>

To comment on this manual write to:

Grizzly Industrial, Inc.  
C/O Technical Documentation  
P.O. Box 2069  
Bellingham, WA 98227-2069

To operate this or any power tool safely and efficiently, it is essential to become as familiar with it as possible. The time you invest before you begin to use your Model G1067Z will be time well spent.

## **WARNING**

**DO NOT operate this machine until you are completely familiar with the contents of this manual. Serious personal injury may occur.**

# Safety Rules For All Tools

## **WARNING**

- 1. KNOW YOUR POWER TOOL.** Read the owner's manual carefully. Learn the tool's applications and limitations, as well as its particular hazards.
  - 2. KEEP ALL GUARDS IN PLACE** and in working order.
  - 3. GROUND ALL TOOLS.** If an adapter is used to accommodate a two-prong receptacle, the adapter plug must be attached to a known ground. Never remove the grounding prong.
  - 4. REMOVE ADJUSTING KEYS AND WRENCHES.** Make it a habit to check that keys and wrenches are removed from the machine before turning it on.
  - 5. KEEP WORK AREA CLEAN.** Cluttered areas and benches invite accidents.
  - 6. AVOID DANGEROUS ENVIRONMENTS.** Do not use power tools in damp or wet locations or expose them to rain. Keep your work area well lighted.
  - 7. KEEP CHILDREN AND VISITORS AWAY.** All children and visitors should be kept a safe distance away from your work area.
  - 8. MAKE WORKSHOP CHILD-PROOF** with padlocks, master switches, or by removable starter keys.
  - 9. DO NOT FORCE TOOL.** Tools work better and safer when they are allowed to perform at their own speed.
  - 10. WEAR PROPER APPAREL.** Do not wear loose clothing, gloves, neckties, or jewelry that can get caught in moving parts. Non-slip footwear must be worn. Long hair should be tied back or wear a hat.
  - 11. NEVER STAND ON, OR LEAN ON THE TOOL.** Doing so could cause injury.
  - 12. USE SAFETY GLASSES AND EAR PROTECTION.** Also use a **DUST MASK** if the operation is dusty.
  - 13. DO NOT OVERREACH.** Keep proper footing and balance at all times.
  - 14. MAINTAIN TOOLS IN TOP CONDITION.** Keep tools sharp and clean for best and safest performance. Follow instructions for lubricating and changing accessories.
  - 15. DISCONNECT TOOLS FROM POWER** before servicing and when changing accessories.
  - 16. AVOID ACCIDENTAL STARTING.** Make sure the switch is in the "OFF" position before plugging in the cord.
  - 17. CHECK DAMAGED PARTS.** Do not operate the machine until you are certain it is in perfect running condition.
  - 18. NEVER LEAVE THE TOOL RUNNING UNATTENDED - TURN POWER OFF.** Do not leave the tool until it comes to a full stop.
  - 19. DO NOT OPERATE THE TOOL IF USING DRUGS, ALCOHOL, OR MEDICATION.**
  - 20. DO NOT WORK IN HASTE** or operate machine if you are fatigued.
  - 21. IF THERE IS SOMETHING YOU DO NOT KNOW OR UNDERSTAND ABOUT THIS TOOL, DO NOT OPERATE IT!** Ask for help first. Confusion can lead to disaster.
  - 22. BAD HABITS ARE DANGEROUS.** Review all safety procedures often.
- These safety rules cannot cover every situation in a woodshop. Consider your conditions when setting up or operating your Wood Lathe.

# Unpacking

---

---

The Model G1067Z Wood Lathe is shipped from the manufacturer in a carefully packed carton. If you discover the machine is damaged after you've signed for delivery, *please call Customer Service immediately for advice.*

Save the containers and all packing materials for possible inspection by the carrier or its agent. *Otherwise, filing a freight claim can be difficult.*

## **WARNING**

**The G1067Z is a heavy machine (190 lbs. shipping weight). DO NOT over-exert yourself while unpacking or moving your machine – get assistance. In the event that your lathe must be moved up or down a flight of stairs, be sure that the stairs are capable of supporting the combined weight of people and the machine. Serious personal injury may occur.**

When you are completely satisfied with the condition of your shipment, you should inventory its parts.



# Piece Inventory

---

---

After all the parts have been removed from the carton, you should have:

- Main Lathe Unit
- On/Off Switch and Front/Rear Covers
- Index Pin
- 6" Face Plate
- 12" Tool Rest
- Tool Rest Support
- Tool Rest Extension
- Knock Out Bar
- Stand Legs (4)
- Stand Support, Long (2)
- Stand Support, Short (2)
- Upper Mount Plate (2)
- End Stand Support (2)

### **Fasteners:**

- |   |    |
|---|----|
| • Carriage Bolt $\frac{5}{16}$ " - 18 x $\frac{3}{4}$ " | 24 |
| • Flat Washer $\frac{5}{16}$ "                          | 32 |
| • Cap Screw $\frac{5}{16}$ " - 18 x 1 $\frac{1}{4}$ "   | 8  |
| • Hex Nut $\frac{5}{16}$ " - 18                         | 32 |
| • Phillips® Head Screw 10 - 24 x $\frac{3}{8}$ "        | 12 |

In the event that any non proprietary parts are missing (e.g. a nut or a washer...), we would be glad to replace them, or, for the sake of expediency, replacements can be obtained at your local hardware store.



# Clean up

---

---

## **WARNING**

The bed and other unpainted parts of the Model G1067Z are coated with a waxy oil that protects them from corrosion during shipment. Remove the protective coating with mineral spirits and paper towels. **DO NOT** use gasoline or other petroleum based solvents because of their extremely low flash points. Serious personal injury may occur. **DO NOT** use chlorine-based solvents – if you happen to splash some onto a painted surface, you will ruin the finish.

## **WARNING**

Follow the safety rules listed below when working with solvents. Failure to do so may result in serious personal injury.

1. Read and follow all directions and warnings on the solvent label.
2. Work only in a well ventilated area.
3. Do not work near any type of open flame (e.g., pilot lights, kerosene heaters, and so on).
4. **DO NOT** smoke while working with flammable material.
5. Paper towels from the cleaning process are extremely combustible. Dispose of waste towels so they do not create a fire hazard.



# Site Considerations

---

---

## **CAUTION**

**Floor Load:** Your G1067Z Lathe represents a large weight load in a small footprint. Most commercial floors are suitable for the Model G1067Z. Some residential floors may require additional build up to support both machine and operator.

**Working Clearances:** Consider existing and anticipated needs, size of material to be processed through each machine, and space for auxiliary stands, work tables or other machinery when establishing a home for your Wood Lathe. Allow sufficient room to safely run your machines in any foreseeable operation.

## **WARNING**

**Lighting and Outlets:** Lighting should be bright enough to eliminate shadow and prevent eye strain. Electrical circuits should be dedicated or large enough to handle amperage requirements. Outlets should be located near each machine so power or extension cords are clear of high-traffic areas. Observe local electrical codes for proper installation of new lighting, outlets, or circuits.



# Circuit Requirements

---

---

## **WARNING**

The motor supplied with the G1067Z is wired for 110V only. Under normal use, the motor draws approximately 10 amps @ 110V. We recommend using a 15 amp circuit breaker or a 20 amp fuse for 110V operation. This should be satisfactory for normal use, while providing enough protection against motor damage caused by power surges. The circuit you use should be dedicated, (i.e., the G1067Z should provide the only draw from that circuit). If frequent circuit failures occur when using the Wood Lathe, contact our service department or your local electrical contractor.

## **WARNING**

This equipment must be grounded. Please ensure that the Wood Lathe is continuously grounded from the motor to the machine frame and then to a known ground. Verify that any existing electrical outlet and circuit you intend to plug into is actually grounded. If it is not, it will be necessary to run a separate 12 A.W.G. copper grounding wire from the outlet to a known ground. Under no circumstances should the grounding pin from any three-pronged plug be removed.

**Extension Cords:** If used, extension cords must be rated Hard Service (grade S) or better. Conductor size must be 14 A.W.G. for cords up to 50 feet in length. Your extension cord must also contain a ground wire and plug pin. Always repair or replace extension cords if they become damaged.

## **WARNING**

Be sure that your particular electrical configuration complies with local and state codes. The best way to ensure compliance is to check with your local municipality or licensed electrician.



# SECTION 2: ASSEMBLY

## Pre-assembly

Assembly of the G1067Z is straightforward. We have organized the assembly process into steps. Please follow them in sequence.

**Tools Required:** Only a few common tools are needed to assemble this machine. Specifically, a 6" adjustable wrench, 12mm open end wrench, regular and Phillips® head screwdriver and an 8mm Allen® wrench.

### **WARNING**

All die-cut metal parts have a sharp edge (called "flashing") on them after they are formed. This is removed at the factory. Sometimes though, a bit of flashing might escape inspection. Please examine the edges of all die-cut metal parts before handling them.



## Stand

1. Locate all four stand legs and the two end panels. Attach an end panel to any two of the legs using the 10 - 24 x  $\frac{3}{8}$ " Phillips® Head Screws provided. **Figure 1.** Repeat this step for the remaining end panel/legs. Do not tighten any fasteners during the assembly of the stand until specifically instructed otherwise.

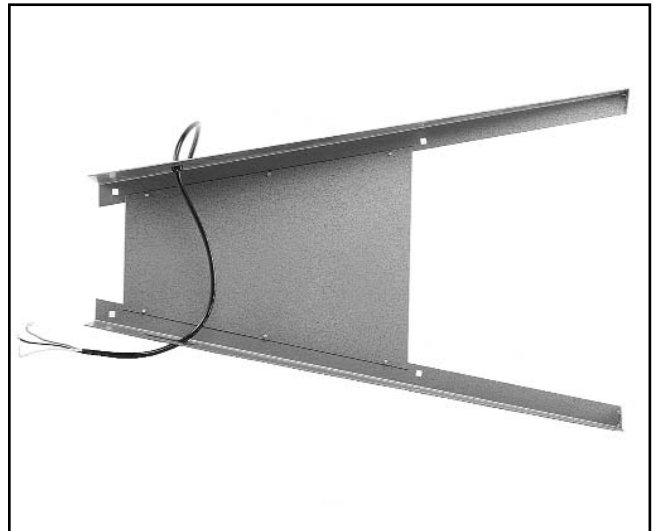

Figure 1.



2. Bolt the upper mount plate and the short stand support to each end assembly using the  $\frac{5}{16}$ " - 18 x  $\frac{3}{4}$ " carriage bolts provided. **Figure 2.**



**Figure 2.**

3. Attach the long stand supports to each end assembly using the  $\frac{5}{16}$ " - 18 x  $\frac{3}{4}$ " carriage bolts provided. **Figure 3.**



**Figure 3.**

4. With an assistant, set the lathe bed assembly on the stand, orienting the front of the headstock with the switch opening in the stand leg. Bolt the lathe bed to the stand using the eight  $\frac{5}{16}$ " - 18 x  $1\frac{1}{4}$ " Cap Screws and Hex Nuts supplied and tighten down. **Figure 4.**

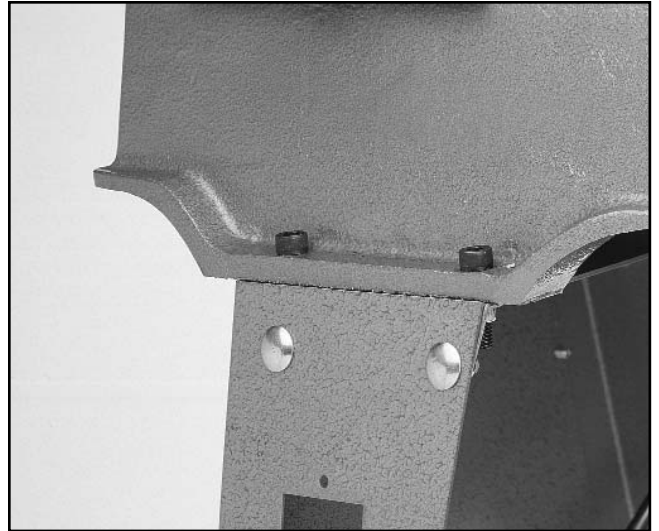

**Figure 4.**

5. At this point tighten down all the bolts on the stand. It is a good idea to do this with the lathe set in place where it will be used.



# Installing the Switch

## **WARNING**

Do not plug cord in until you are ready to test run the lathe. See Test Run section for instructions before initial run.

1. Locate the on/off switch and the front and rear covers which will be held in place by two Phillips® head screws.
2. Make sure the wiring from the switch goes through the rear cover box. Position the switch in the opening in the left front leg of the stand. **Figure 5.** Attach the two green ground wires to the stand (see arrow) using the Phillips® screw provided.
3. Line up the front cover, the switch and the rear cover with the holes in the stand and attach using two 10 - 24 x 1" Phillips® head screws and nuts.
4. Locate the plug-in connector coming from the motor and connect it with the connector coming from the switch. **Figure 6** shows a properly assembled switch and the connector.

## **WARNING**

**This equipment must be grounded.** Please ensure that this machine is continuously grounded from the motor to the machine frame and then to a known ground. Verify that any existing electrical outlet and circuit you intend to plug into is actually grounded. If it is not, it will be necessary to run a separate 12 A.W.G. copper grounding wire from the outlet to a known ground. Under no circumstances should the grounding pin from any three-pronged plug be removed. **Serious injury may occur.**



**Figure 5.**

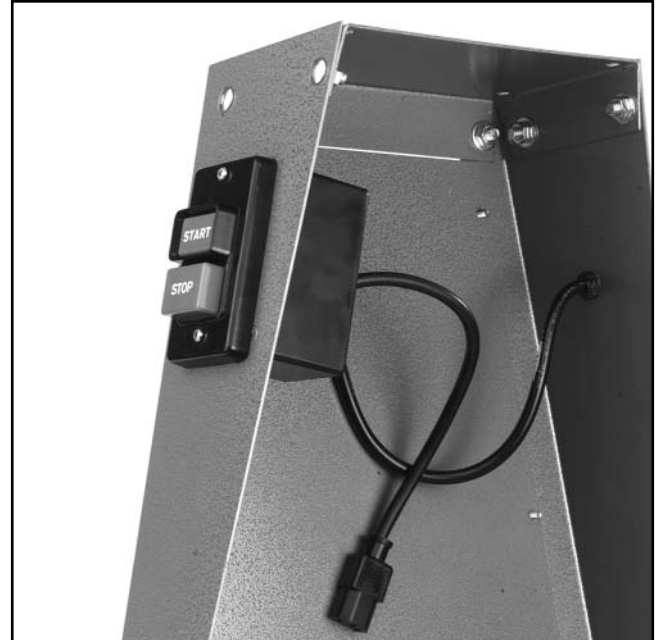

**Figure 6.**



# Tool Rest

---

---

The tool rest is equipped with a cam-action clamping system to secure it to the lathe bed. When the lever is thrown, a locking plate lifts up and secures the tool rest to the bed. To install the tool rest assembly:

1. Remove the large Hex Nut and lock plate from the bottom of the tool rest assembly.
2. Set the tool rest assembly on the lathe bed with the clamp stud between the bed slot.
3. Set the tool rest lock handle so it is pointing down. Re-install the lock plate and thread the Hex Nut back onto the stud until it bottoms out.
4. Lift the lock handle approximately 90° and tighten the Hex Nut  $\frac{1}{2}$  to  $\frac{2}{3}$  of a turn more.
5. Turn the tool rest lock handle until it locks the tool rest down onto the bed. You may need to adjust the Hex Nut in small increments to fine tune how the tool rest assembly locks down onto the bed.



Figure 7.



# Tailstock

---

---

Thread the handle onto the tailstock handwheel and tighten down the jamnut. **Figure 8.**

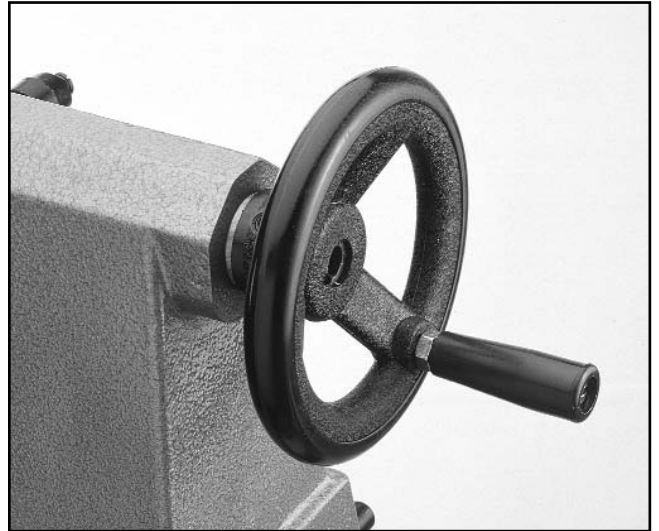
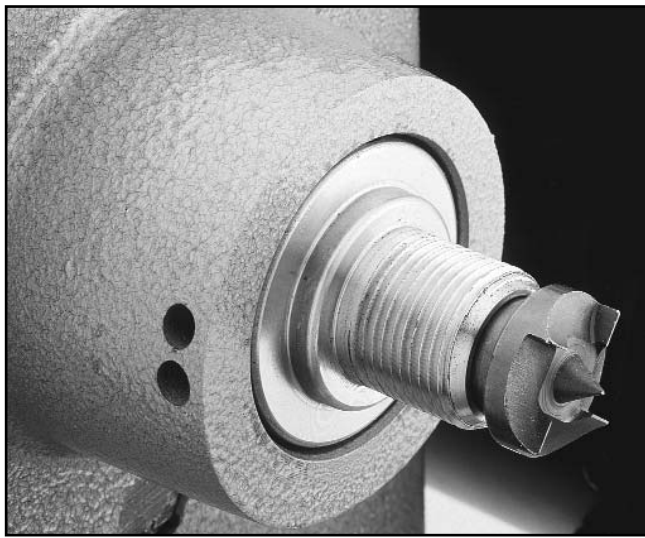

Figure 8.



# Spur Center

The G1067Z is supplied with a #2 Morse taper spur center for use when spindle turning. The spur center is used in conjunction with the tailstock live center. Install the spur center by inserting into the hole in the inboard spindle. **Figure 9.**



**Figure 9.**

To remove: insert the knockout bar provided into the outboard spindle and tap with the palm of your hand while carefully holding onto the spur center with your other hand. **Figure 10.**

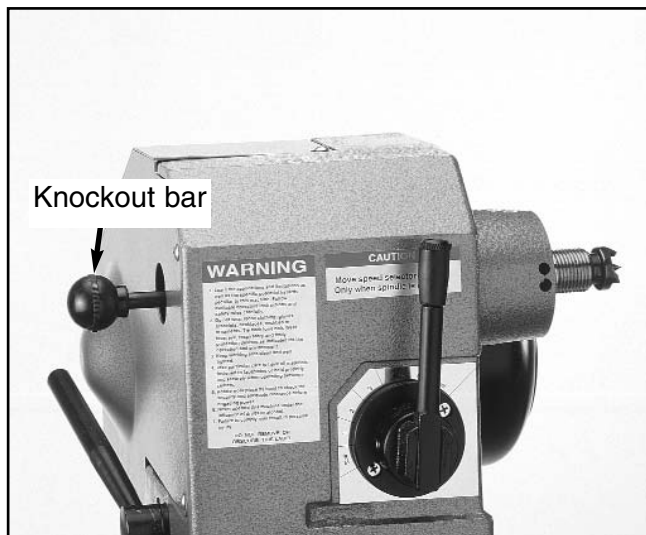
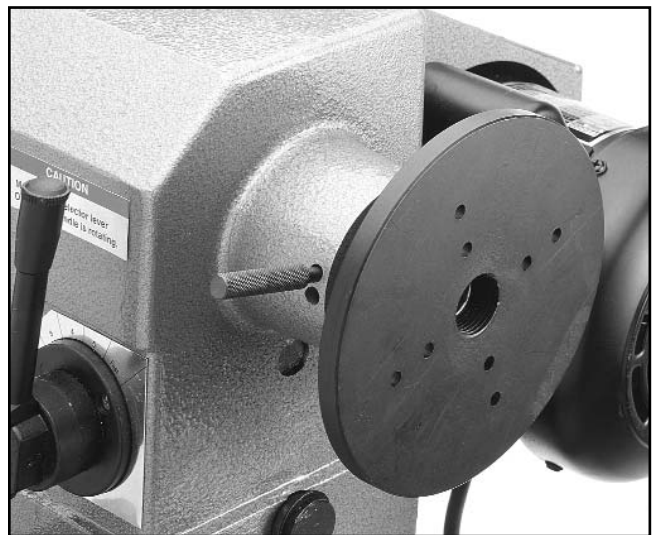

**Figure 10.**



# Face Plate

The G1067Z is supplied with a 6" face plate. The faceplate is used for bowl and plate turning. Install the face plate by threading the face plate onto the inboard spindle. Use the indexing pin to hold the spindle from rotating while tightening down or removing the face plate. **Figure 11.** Do not use the face plate in conjunction with the spur center. Mount your workpiece to the face plate using the mounting holes bored into the face plate.



**Figure 11.**



# SECTION 3: ADJUSTMENTS

## Headstock

The Model G1067Z headstock can be swiveled 180° as well as positioned anywhere along the bed.

### To position the headstock along the bed:

1. Loosen the quick release lever by pushing it down. **Figure 12.**
2. Move the headstock to the desired position and re-engage the quick release lever. **Figure 13.** **Note:** The large Hex Nut under the headstock will require occasional adjusting to assure proper clamping pressure to the bed. Turn the Hex Nut in small increments to fine tune the clamping pressure.

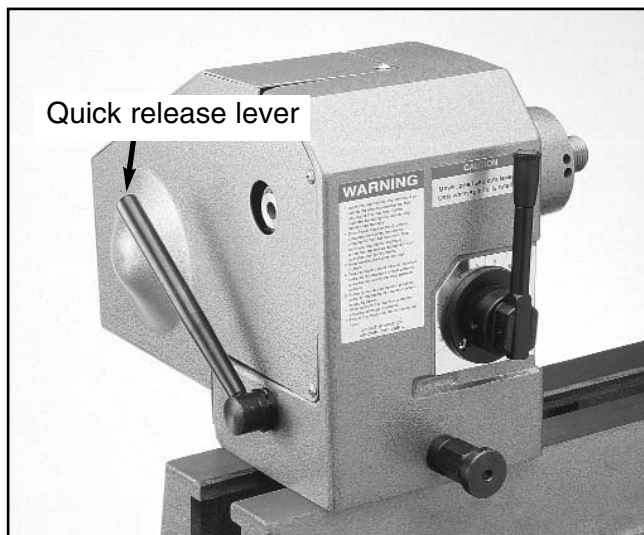

Figure 12.

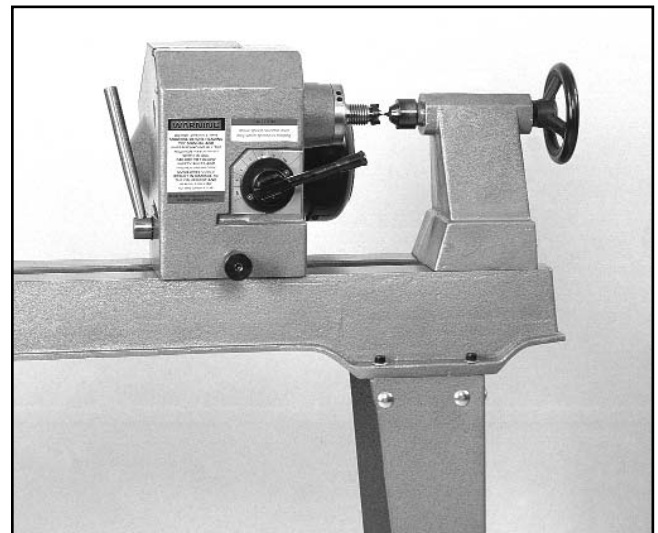

Figure 13.

### To swivel the headstock:

1. Loosen the quick release lever by pushing it down.
2. Pull the spring loaded quick release set pin (**Figure 14**) and rotate the headstock clockwise 90° or 180°.

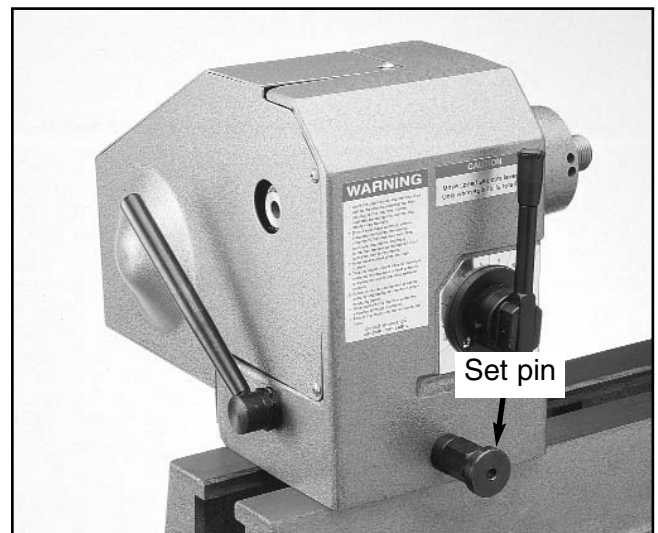
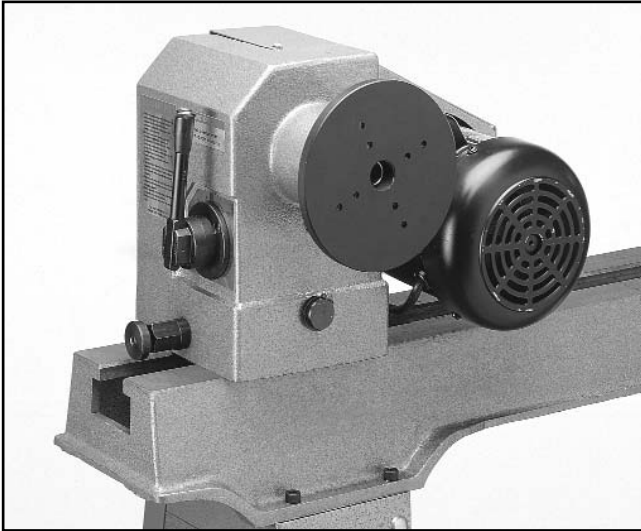

Figure 14.

3. Release the set pin. Make sure the set pin has engaged in its detent by trying to rotate the headstock.
4. Now position the head stock along the bed as desired and engage the quick release lever.

**! WARNING**

**Never operate the lathe with the quick release lever loose. Serious personal injury may occur.**



**Figure 15.** Headstock set at 90°.



**Figure 16.** Headstock set at 180°.



# Tailstock

The tailstock is equipped with a cam-action clamping system to secure it to the lathe bed. When the lever is thrown, a locking plate lifts up and secures the tool rest to the bed. To position the tailstock along the bed:

1. Loosen the quick release lever and move the tailstock to the desired position. **Figure 17.**
2. Re-engage the quick release lever.
3. If the quick release lever will not lock the tailstock down onto the bed (either too loose or too tight), loosen or tighten the Hex Nut (located on the underside of the tailstock) in small increments as needed to achieve the proper clamping pressure.

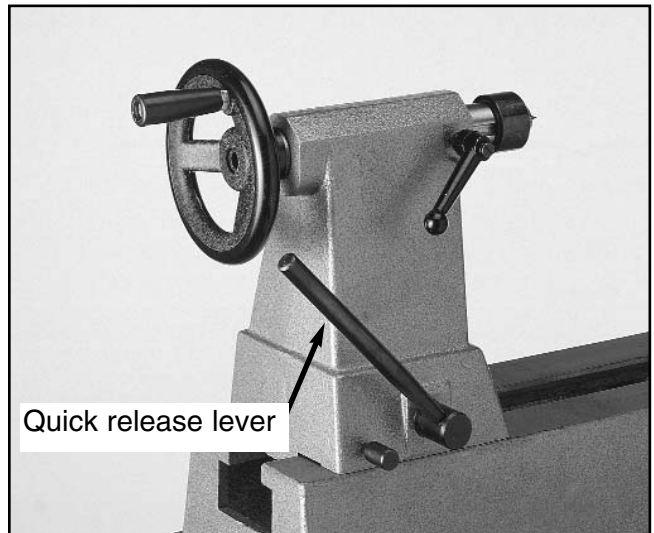

**Figure 17.**



# Live Center

A #2 Morse taper live center is supplied with the lathe and is preinstalled from the factory. **Figure 18.** To remove it:

1. Turn the handwheel counter-clockwise until the tailstock barrel bottoms out in the tailstock housing. This causes the center to be forced out of the barrel.
2. Reinstall by turning the handwheel clockwise until the tailstock barrel sticks out of the tailstock housing about  $\frac{1}{2}$ ". Insert the live center back into the tailstock barrel.

## WARNING

(1) The tailstock barrel lock handle must always be locked down while the lathe is in use. **Figure 18.** The workpiece can be thrown from the lathe if this step is not observed. (2) The tailstock barrel should not protrude from the tailstock housing more than 2". Serious personal injury may occur.

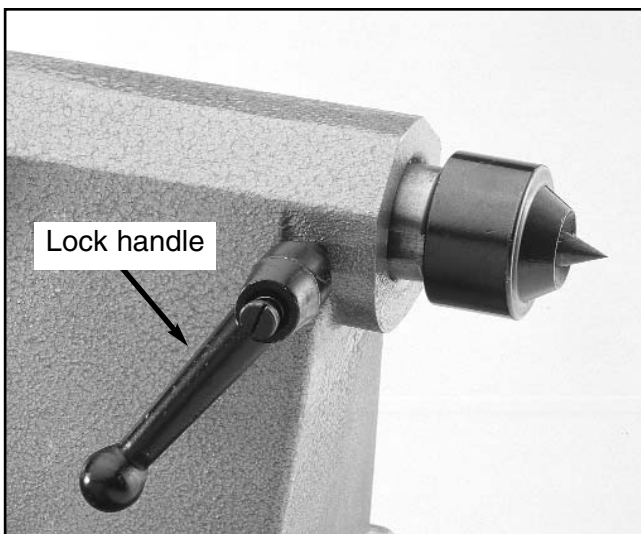

**Figure 18.**



# Speed Selector

## CAUTION

The lathe must be running to change speeds. Before turning the lathe on, read **Safety Rules and Test Run** in the **Operations Section, page 15 and 16.**

The variable speed selector has six position settings. These settings provide speeds of 500, 800, 1200, 1600, 2000 and 2700 RPM for varied applications. To change speeds:

1. Turn the lathe on.
2. Pull the speed selector lever straight back away from the machine so the detent spring compresses. **Figure 19.**
3. Slowly shift the lever to the desired speed.
4. Make sure the lever is set in the detent for the desired speed. The lever should click into position.

## CAUTION

Remember to choose the correct speed for your particular turning project. As a general rule, the larger the workpiece diameter, the slower the speed. Always start on slow speed.

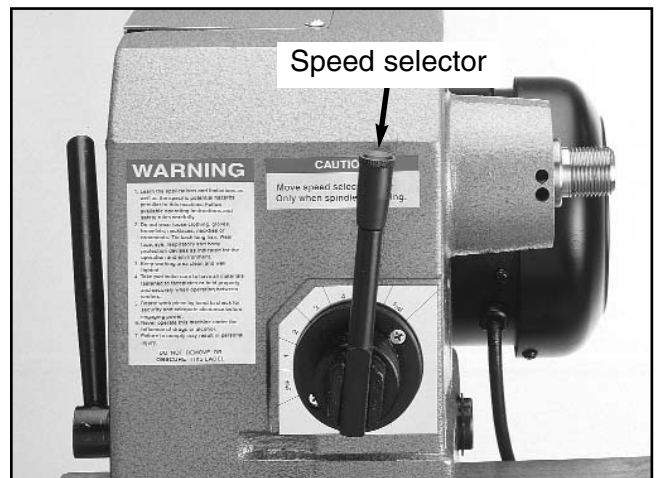

**Figure 19.**



# SECTION 4: OPERATIONS

## Safety Rules For Wood Lathes

### **WARNING**

Always wear ANSI-approved safety glasses or goggles and hearing protection when operating equipment — particularly when testing new tools or machinery. Do not allow visitors into your workshop when testing or operating equipment. Serious personal injury may occur.

### **WARNING**

The Model G1067Z is capable of causing serious personal injury if used in a reckless manner. Please follow the previously-mentioned safety rules for all tools, as well as these safety guidelines for Wood Lathes:

1. Observe all electrical requirements such as fuse sizing, wire sizing, grounding and any other electrical consideration.
2. Ensure that all guards are in place and that the Wood Lathe sets on a flat, stable surface.
3. Always wear eye protection when operating a Wood Lathe. Use a respirator to avoid inhaling dust. All safety equipment should be ANSI approved.
4. Always observe the condition of the materials you are turning. Pay particular attention to knots, splits and other potentially dangerous conditions.
5. Never operate the lathe with damaged or worn parts.
6. Maintain your lathe in proper working condition. Perform routine inspections and maintenance promptly when called for. Put away adjustment tools after use.
7. Make sure your Wood Lathe is turned off, disconnected from its power source and all moving parts have come to a complete stop before starting any inspection, adjustment, or maintenance procedure.
8. Allow the lathe to gain its full speed before beginning turning.
9. Do not leave lathe running unattended for any reason.
10. Do not stop lathe by putting your hand against the workpiece.
11. Discourage visitors, particularly children, from your work area while you are working. If visitors must be in your shop while you work, make sure that they are provided with ANSI-approved safety protection.
12. Remove indexing pin before turning lathe on.
13. Test your tool rest clearance by rotating workpiece by hand before turning lathe on.
14. When face plate turning, use lathe chisels on the downward spinning side of the workpiece only.
15. Always support lathe chisels on the tool rest.

Remember that every shop has its own specific hazards. Be sure, above all else, to use good common sense and reasonable caution each time you start this lathe, or any woodworking machinery. Proper safety standards rarely take any more time or energy when followed religiously. Develop a habit of safety.



---

---

## Test Run

Once the assembly is complete and the adjustments are done to your satisfaction, you are ready to test the machine.

### CAUTION

Turn on the power supply at the main panel. Press the START button. Make sure that your finger is poised on the STOP button, just in case there's a problem. The Wood Lathe should run smoothly, with little or no vibration or rubbing noises. Strange or unnatural noises should be investigated and corrected before operating the machine further.

### WARNING

DO NOT attempt to investigate or adjust the machine while it is running. Wait until the machine is turned off, unplugged and all working parts have come to a rest before you do anything! Serious personal injury may occur.

If noises occur that cannot be found by visual inspection, feel free to contact our service department for help.

### CAUTION

If the lathe runs smoothly, try mounting a piece of turning stock. If a problem exists, stop the machine and review all the adjustments. Call for assistance, if needed.



---

---

## Tool Rest

Adjust the tool rest as close to the workpiece as possible without actually coming in contact with the workpiece. Test by hand turning the workpiece before turning lathe on. Ensure that the lathe chisel is fully supported by the tool rest. Support the lathe chisel on the tool rest with one hand, while controlling the chisel with the other hand. **Figure 20.** For outboard turning, it may be desirable to use a free standing tool rest.

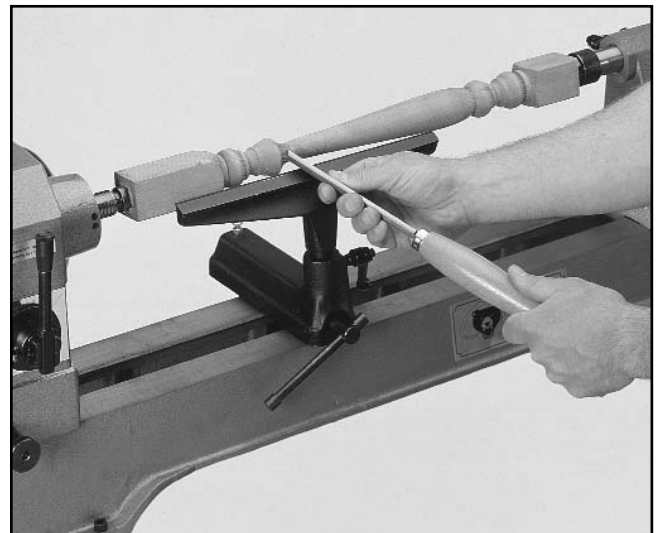

Figure 20.



# Spindle Turning

---

---

Spindle turning is described as turning work between the two centers. Turning a spindle can be a very simple or a highly intricate operation. To mount a workpiece between centers:

1. Locate the center point on both ends of the workpiece by carefully drawing diagonal lines from corner to corner. The point of intersection is the center of the work.
2. Hold the spindle vertically and support it on a solid surface. Line up the spur center with the center of the workpiece. Drive the spur center into the stock about  $\frac{1}{4}$ " using a dead blow hammer. Be careful not to split the workpiece. Wood with splits along the grain may fly off the lathe during operation. For dense wood, drill a hole for the center and score lines with a saw blade for the spurs.

3. Once the spur center is firmly attached to the workpiece, insert the spur center (with the attached workpiece) into the headstock spindle.
4. While supporting the workpiece, slide the tailstock close to the end of the workpiece and lock into place.
5. Line up the live center with the workpiece center. Turn the handwheel to press the point of the live center into the workpiece.

## **WARNING**

**Do not press too firmly or the bearings will bind and overheat, On the other hand, do not adjust too loosely or the workpiece will spin off the lathe. Use good judgement. Serious personal injury may occur.**

6. Lock the tailstock barrel in place.

## **WARNING**

**Make sure the live center in the tailstock lines up with the spur center in the headstock before turning anything between centers. Failure to observe this step could result in the workpiece being thrown from the lathe. Serious personal injury may occur.**



# Outboard Turning

Outboard turning is usually done when stock diameter is greater than 12". For the size of this particular lathe and its minimum turning speed, we recommend a maximum diameter of 17" and a maximum thickness of 2".

**Figure 21** depicts the lathe setup for turning a bowl using the tool rest extension supplied.

**Figure 22** depicts the lathe setup for turning a bowl using a free standing tool rest (not supplied).

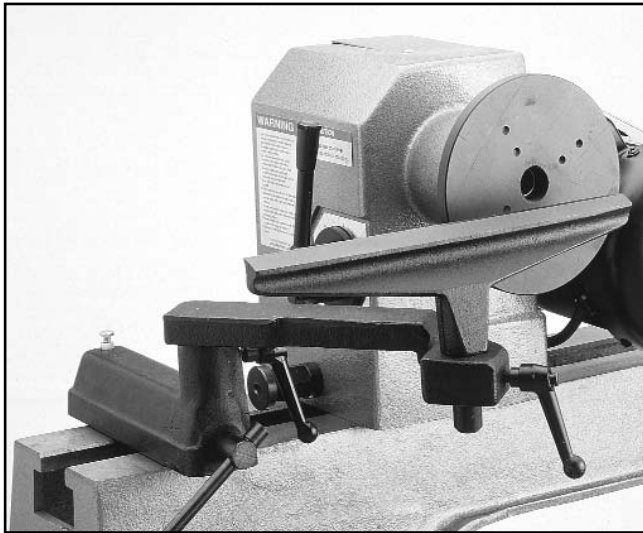

**Figure 21.** Headstock set at 90°.



**Figure 22.** Headstock set at 180°.



# Indexing

The headstock spindle indexes every 15° by inserting the indexing pin into one of the holes in the headstock. Indexing is desirable when locking the workpiece in position such as when routing flutes. The spindle is drilled every 30° and the headstock housing has two holes that are drilled 15° apart. To index the spindle:

1. Insert the pin through the hole in the housing.
2. Rotate the spindle by hand until the pin drops into a hole in the spindle. **Figure 23.**

## **WARNING**

**Never start the lathe with the indexing pin inserted in the indexing hole. Serious personal injury may occur.**



**Figure 23.** Spindle indexing.



# SECTION 5: MAINTENANCE

## General

### **WARNING**

Before performing any type of inspection or maintenance work on this lathe, be sure that the power cord is unplugged and all moving parts have come to a complete stop. Serious personal injury may occur.

Make a habit of inspecting your lathe each time you use it. Check for the following conditions and repair or replace when necessary.

1. Loose mounting bolts.
2. Worn switch.
3. Worn or damaged cords and plugs.
4. Any other condition that could hamper the safe operation of this machine.



## Bed

The bed and other non-painted surfaces on the Model G1067Z should be protected against rust and pitting. Wiping the lathe clean after every use ensures that moisture from wood dust isn't allowed to trap moisture against bare metal surfaces.



## Lubrication

The G1067Z Lathe is equipped with a split pulley system which allows the speed of the lathe to be changed while its running. To assure the smooth operation of this pulley system, we recommend the main spindle and motor spindle be greased occasionally. To do this, remove the pulley cover, vacuum out any saw dust and apply grease to the spots indicated in **Figure 24**. Disposable acid brushes work best to get into these hard to reach places.

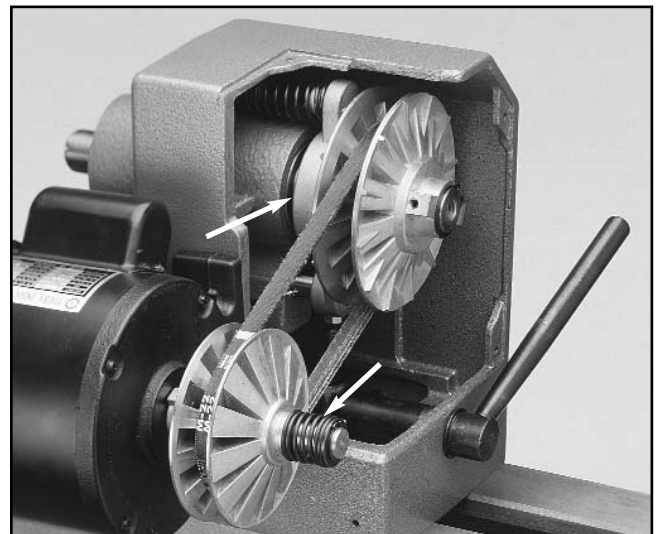

**Figure 24.**

Shielded and pre-lubricated ball bearings require no lubrication for the life of the bearings. In a continuous-use environment, expect the bearings to last for several years. With intermittent use, bearings can be expected to last much longer. All bearings are common sizes and can be easily obtained.



# SECTION 6: CLOSURE

---

The following pages contain general machine data, parts diagram, parts list and Warranty/Return information for your Model G1067Z Lathe.

If you need parts or help in assembling your machine, or if you need operational information, we encourage you to call the appropriate regional Service Department. Our trained service technicians will be glad to help you.

If you have comments dealing specifically with this manual, please write to our Bellingham, Washington location using the address in the Introduction. The specifications, drawings, and photographs illustrated in this manual represent the Model G1067Z as supplied when the manual was prepared. However, due to Grizzly's policy of continuous improvement, changes may be made at any time with no obligation on the part of Grizzly. Whenever possible, though, we send manual updates to all owners of a particular tool or machine. Should you receive one, add the new information to this manual and keep it for reference.

We have included some important safety measures that are essential to this machine's operation. While most safety measures are generally universal, Grizzly reminds you that each workshop is different and safety rules should be considered *as they apply to your specific situation*.

We recommend you keep a copy of our current catalog for complete information regarding Grizzly's warranty and return policy. If you need additional technical information relating to this machine, or if you need general assistance or replacement parts, please contact the appropriate regional Service Department listed in the introduction.

Additional information sources are necessary to realize the full potential of this machine. Trade journals, woodworking magazines, and your local library are good places to start.

## **WARNING**

**Like all power tools, there is danger associated with the Model G1067Z Lathe. Use the tool with respect and caution to lessen the possibility of mechanical damage or operator injury. If normal safety precautions are overlooked or ignored, serious personal injury may occur.**

## **WARNING**

**The Model G1067Z was specifically designed for turning operations. Do not modify and/or use this Lathe for any other purpose. If you are confused about any aspect of this machine, DO NOT use it until you have answered all your questions. Serious personal injury may occur.**

## **NOTE**

**Modifications or improper use of this tool will void the warranty.**



# MACHINE DATA SHEET

Customer Service #: (570) 326-3806 • To Order Call: (800) 523-4777 • Fax #: (800) 438-5901

## GRIZZLY MODEL G1067Z HEAVY-DUTY WOOD LATHE

Design Type .....Floor Model

**Overall Dimensions:**

Including Stand .....45<sup>3</sup>/<sub>4</sub>" H x 20" W x 58<sup>3</sup>/<sub>4</sub>" L  
 Swing Over Bed.....14"  
 Swing Over Gap .....17"  
 Distance Between Centers .....40"  
 Shipping Weight .....190 lbs.  
 Weight in Place .....179 lbs.

**Construction:**

Bed .....Precision Ground Cast Iron  
 Headstock .....Cast Iron  
 Stand .....Pre-Formed Sheet Steel  
 Spindle.....Shielded & Lubricated-For-Life Ball Bearings

**Specifications:**

Spindle Size .....1" x 12 TPI RH  
 Bore Through Spindle .....0.406"  
 Tailstock Taper .....MT #2  
 Spindle Taper.....MT #1 Spur Center  
 Number / Range of Speeds .....6 / 600 to 2100 RPM

**Motor:**

Type .....TEFC Capacitor Start Induction  
 Horsepower .....<sup>1</sup>/<sub>2</sub> HP  
 Phase / Cycle .....Single Phase / 60 Hz  
 Voltage .....110 v  
 Amps .....8  
 RPM .....1720  
 Bearings .....Shielded & Lubricated-For-Life Ball Bearings  
 Switch .....Safety Key Toggle Switch

**Standard Features:**

.....Swivel Head  
 .....6" Face Plate  
 .....Articulated Tool Rest Support

*Specifications, while deemed accurate, are not guaranteed.*

REVISED 2/99

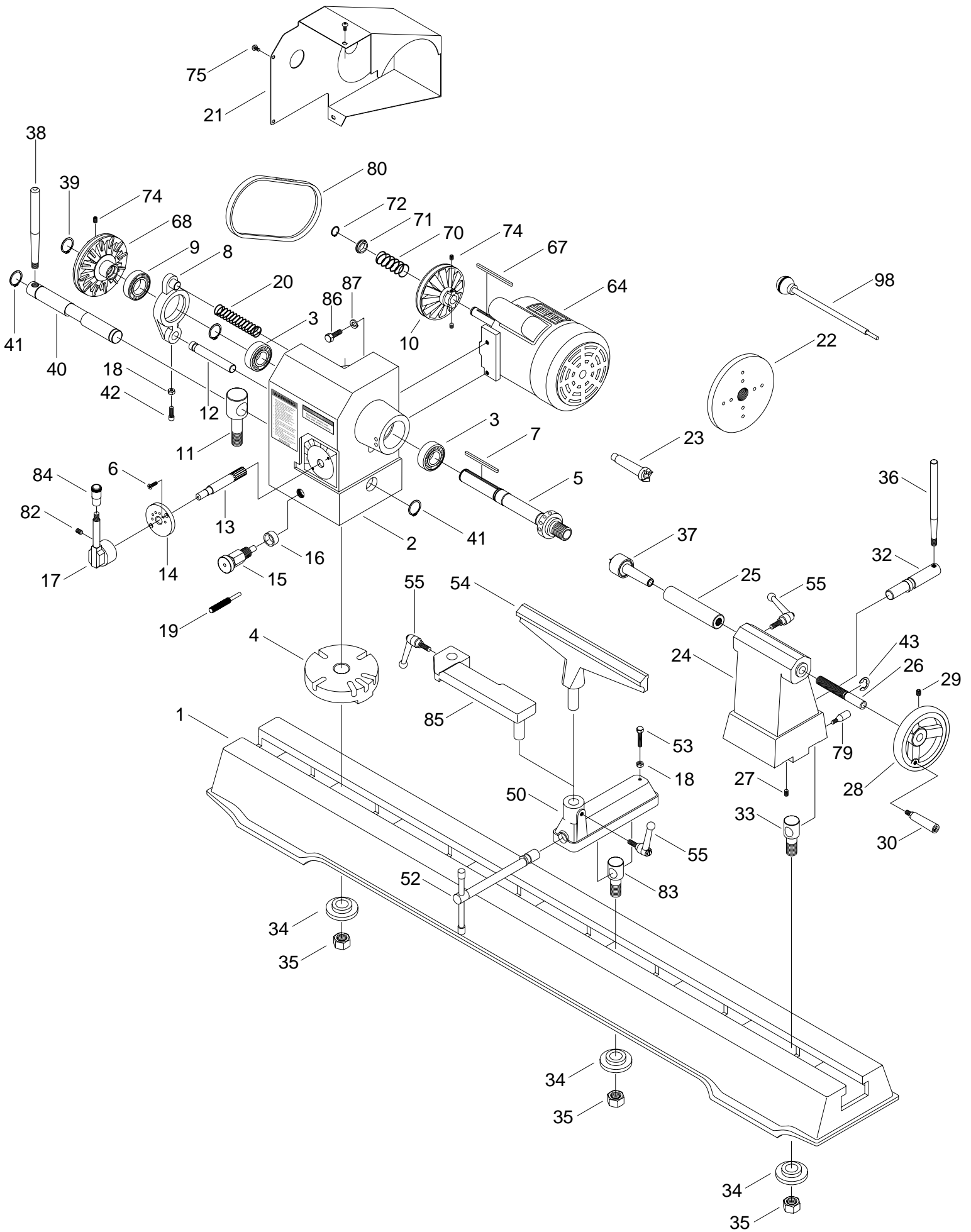

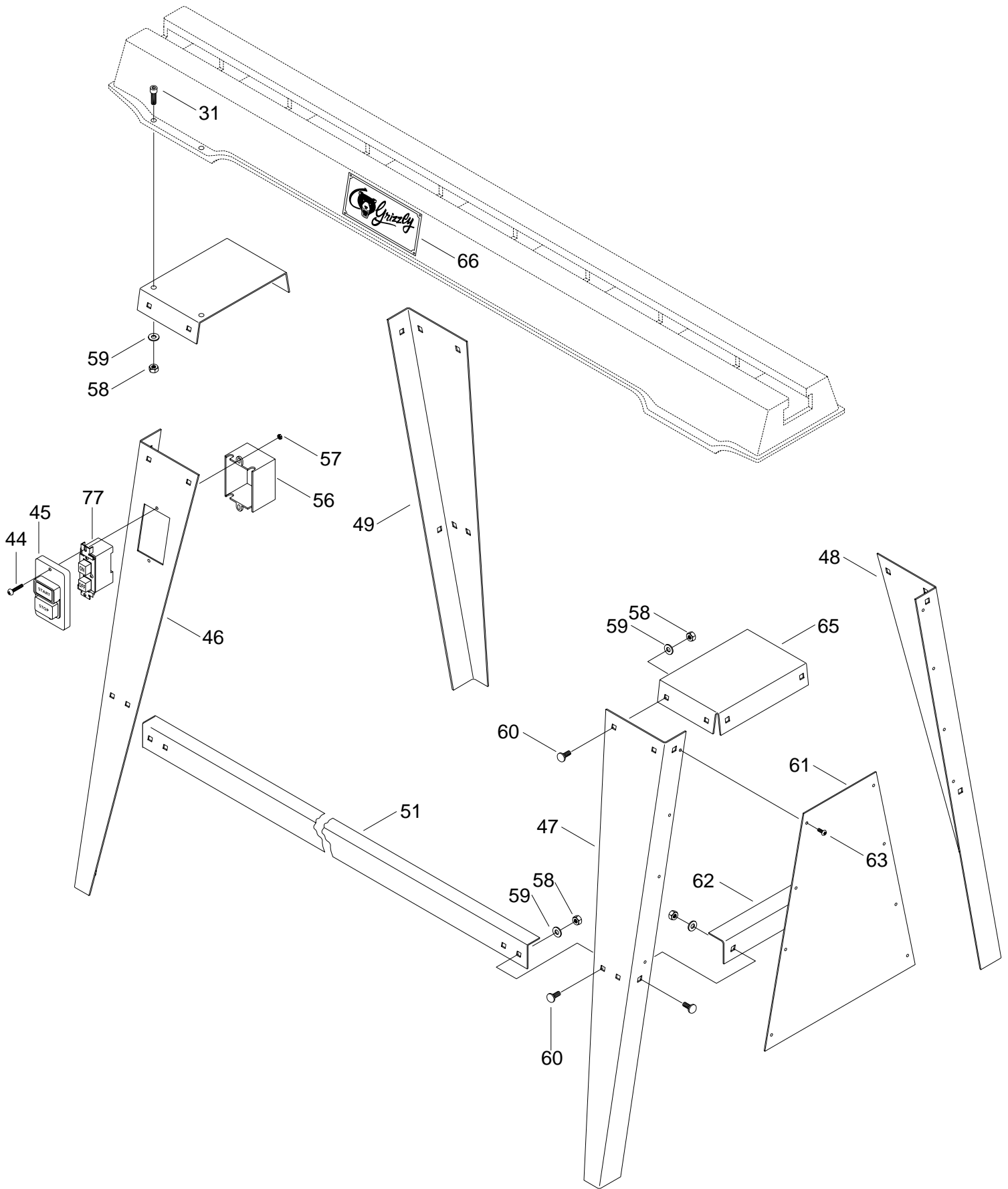



REF	PART #	DESCRIPTION	REF	PART #	DESCRIPTION
1	P1067Z001	BED	45	P1019090B	PLASTIC SWITCH COVER
2	P1067Z002	HEADSTOCK	46	P1067Z046	LEG, LEFT FRONT
3	P6205	BEARING 6205-2RS	47	P1067Z047	LEG, RIGHT FRONT
4	P1067Z004	INDEXING BLOCK	48	P1067Z048	LEG, RIGHT REAR
5	P1067Z005	MAIN SPINDLE	49	P1067Z047	LEG, LEFT REAR
6	PFH08	FLAT HD SCR 10-24 X 1/2"	50	P1495050	TOOL REST HOUSING
7	P1067Z007	KEY 4 X 4 X 74	51	P1067Z051	CROSS BRACE, LONG
8	P1067Z008	BRACKET	52	P1495051	ECCENTRIC ROD W/052
9	P6006	BEARING 6006-2RS	53	PB31	HEX BOLT 1/4"-20 x 1"
10	P1067Z010	SPINDLE PULLEY SET	54	P1174071	TOOL REST W/070
11	P1067Z011	LOCKING STUD	55	P1495031	LOCKING LEVER
12	P1067Z012	SHIFTING ROD	56	P1067Z056	REAR SWITCH COVER
13	P1067Z013	PINION SHAFT	57	PN07	HEX NUT 10-24
14	P1067Z014	INDEXING PLATE	58	PN02	HEX NUT 5/16"-18
15	P1067Z015	DETENT PIN ASSEMBLY	59	PW07	FLAT WASHER 5/16"
16	P1067Z016	COLLAR	60	PCB01	CARRIAGE BOLT 5/16"-18 x
17	P1067Z017	SPEED CHANGE LEVER	5/8"		
18	PN05	HEX NUT 1/4"-20	61	P1067Z061	END PANEL
19	P1067Z019	INDEXING PIN	62	P1067Z062	CROSS BRACE, SHORT
20	P1067Z020	SPRING	63	PS06	PHLP HD SCR 10-24 x 3/8"
21	P1067Z021	PULLEY COVER	64	P1067Z064	MOTOR
22	P1495022	FACE PLATE	65	P1067Z065	TOP BRACE
23	G2522	SPUR CENTER	66	P1067Z066	NAME PLATE
24	P1067Z024	TAILSTOCK HOUSING	67	P1067Z067	KEY 4 X 4 X 84
25	P1495025	TAILSTOCK BARREL	68	P1067Z068	MOTOR PULLEY SET
26	P1495026	TAILSTOCK LEAD SCREW	69	P1067Z069	SPEED CHART *
27	PSS03	SET SCREW 1/4"-20 x 3/8"	70	P1067Z070	SPRING
28	P1495028	HAND WHEEL	71	P1067Z071	SPRING RETAINER
29	PSS17	SET SCREW 5/16"-18 x 5/16"	72	PR06M	SNAP RING 16MM
30	P1495030	HANDLE	73	P1067Z073	CAUTION LABEL *
31	P1067Z031	STOP BAR	74	PSS11	SET SCREW 1/4"-20 x 1/4"
32	P1067Z032	CAM SLIDE BAR	75	PS06	PHLP HD SCR 10-24 x 3/8"
33	P1067Z033	LOCK STUD	76	P1067Z076	POWER CORD *
34	P1495034	LOCKING PLATE	77	P1019090A	ON/OFF SWITCH
35	PN17	HEX BOLT 3/4"-10	78	P1067Z078	SAFETY LABEL *
36	P1495036	HANDLE	79	P1067Z079	STOP BAR
37	G1807	LIVE CENTER	80	PVM22	V-BELT M-22
38	P1067Z038	LOCK LEVER	82	PSS02	SET SCREW 5/16"-18 x 3/8"
39	P1067Z039	SNAP RING 24MM	83	P1495083	LOCKING STUD
40	P1067Z040	ECCENTRIC SHAFT	84	P1067Z084	KNOB
41	PR11M	SNAP RING 25MM	85	P1067Z085	TOOL REST EXTENSION
42	PSB06	CAP SCREW 1/4"-20 x 1"	86	PB03	HEX BOLT 5/16"-18 x 1"
43	PEC04M	E-CLIP 13MM	87	PLW01	LOCK WASHER 5/16"
44	PS03	PHLP HD SCR 10-24 x 1"	98	P1067Z098	KNOCK OUT BAR

Parts noted with an asterisk (\*) are not shown on the exploded views.

# WARRANTY CARD

Name \_\_\_\_\_  
Street \_\_\_\_\_  
City \_\_\_\_\_ State \_\_\_\_\_ Zip \_\_\_\_\_  
Phone Number \_\_\_\_\_ E-Mail \_\_\_\_\_ FAX \_\_\_\_\_  
MODEL # \_\_\_\_\_ Order # \_\_\_\_\_

The following information is given on a voluntary basis. It will be used for marketing purposes to help us develop better products and services. Of course, all information is strictly confidential.

- How did you learn about us?  
 Advertisement  Friend  
 Catalog  Card Deck  
 World Wide Web  
 Other \_\_\_\_\_
- Which of the following magazines do you subscribe to.  
 American Woodworker  Practical Homeowner  
 Cabinetmaker  Shop Notes  
 Family Handyman  Today's Homeowner  
 Fine Homebuilding  WOOD  
 Fine Woodworking  WoodenBoat  
 Home Handyman  Woodshop News  
 Journal of Light Construction  Woodsmith  
 Old House Journal  Woodwork  
 Popular Mechanics  Woodworker  
 Popular Science  Woodworker's Journal  
 Popular Woodworking  Workbench  
 Other \_\_\_\_\_
- Which of the following woodworking/remodeling shows do you watch?  
 Backyard America  The New Yankee Workshop  
 Home Time  This Old House  
 The American Woodworker  Woodwright's Shop  
 Other \_\_\_\_\_
- What is your annual household income?  
 \$20,000-\$29,999  \$60,000-\$69,999  
 \$30,000-\$39,999  \$70,000-\$79,999  
 \$40,000-\$49,999  \$80,000-\$89,999  
 \$50,000-\$59,999  \$90,000 +
- What is your age group?  
 20-29  50-59  
 30-39  60-69  
 40-49  70 +
- How long have you been a woodworker?  
 0 - 2 Years  8 - 20 Years  
 2 - 8 Years  20+ Years
- How would you rank your woodworking skills?  
 Simple  Advanced  
 Intermediate  Master Craftsman
- What stationary woodworking tools do you own? Check all that apply.  
 Air Compressor  Panel Saw  
 Band Saw  Planer  
 Drill Press  Power Feeder  
 Drum Sander  Radial Arm Saw  
 Dust Collector  Shaper  
 Horizontal Boring Machine  Spindle Sander  
 Jointer  Table Saw  
 Lathe  Vacuum Veneer Press  
 Mortiser  Wide Belt Sander  
 Other \_\_\_\_\_
- How many of your woodworking machines are Grizzly? \_\_\_\_\_
- Which benchtop tools do you own? Check all that apply.  
 1" x 42" Belt Sander  6" - 8" Grinder  
 5" - 8" Drill Press  Mini Lathe  
 8" Table Saw  10" - 12" Thickness Planer  
 8" - 10" Bandsaw  Scroll Saw  
 Disc/Belt Sander  Spindle/Belt Sander  
 Mini Jointer  
 Other \_\_\_\_\_
- How many of the machines checked above are Grizzly? \_\_\_\_\_
- Which portable/hand held power tools do you own? Check all that apply.  
 Belt Sander  Orbital Sander  
 Biscuit Joiner  Palm Sander  
 Circular Saw  Portable Planer  
 Detail Sander  Saber Saw  
 Drill/Driver  Reciprocating Saw  
 Miter Saw  Router  
 Other \_\_\_\_\_
- What machines/supplies would you like Grizzly Industrial to carry?  
 12" Table Saw  Radial Arm Saw  
 12" Jointer  Panel Saw  
 Combination Planer/Joiner  Brass Hardware  
 Paint & Finishing Supplies  Lumber  
 Contractor's Supplies  
 Other \_\_\_\_\_
- What new accessories would you like Grizzly Industrial to carry?  
 Builders Hardware  Hand Tools  
 Fasteners  Wood Components  
 Other \_\_\_\_\_
- What other companies do you purchase your tools and supplies from?  
\_\_\_\_\_  
\_\_\_\_\_
- Do you think your purchase represents good value?  
 Yes  No
- Would you recommend Grizzly Imports to a friend?  
 Yes  No
- Would you allow us to use your name as a reference for Grizzly customers in your area? **Note: We never use names more than three times.**  
 Yes  No
- Comments: \_\_\_\_\_  
\_\_\_\_\_  
\_\_\_\_\_  
\_\_\_\_\_

CUT ALONG DOTTED LINE

FOLD ALONG DOTTED LINE

---

---

---

Place  
Stamp  
Here



**GRIZZLY INDUSTRIAL, INC.**  
**P.O. BOX 2069**  
**BELLINGHAM, WA 98227-2069**

FOLD ALONG DOTTED LINE

Send a Grizzly Catalog to a friend:

Name _____
Street _____
City _____ State _____ Zip _____

TAPE ALONG EDGES--PLEASE DO NOT STAPLE

# WARRANTY AND RETURNS

---

---

Grizzly Industrial, Inc. warrants every product it sells for a period of **1 year** to the original purchaser from the date of purchase. This warranty does not apply to defects due directly or indirectly to misuse, abuse, negligence, accidents, repairs or alterations or lack of maintenance. This is Grizzly's sole written warranty and any and all warranties that may be implied by law, including any merchantability or fitness, for any particular purpose, are hereby limited to the duration of this written warranty. We do not warrant or represent that the merchandise complies with the provisions of any law or acts unless the manufacturer so warrants. In no event shall Grizzly's liability under this warranty exceed the purchase price paid for the product and any legal actions brought against Grizzly shall be tried in the State of Washington, County of Whatcom.

We shall in no event be liable for death, injuries to persons or property or for incidental, contingent, special, or consequential damages arising from the use of our products.

To take advantage of this warranty, contact us by mail or phone and give us all the details. We will then issue you a "Return Number", which must be clearly posted on the outside as well as the inside of the carton. We will not accept any item back without this number. Proof of purchase must accompany the merchandise.

The manufacturers reserve the right to change specifications at any time because they constantly strive to achieve better quality equipment. We make every effort to ensure that our products meet high quality and durability standards and we hope you never need to use this warranty.

Please feel free to write or call us if you have any questions about the machine or the manual.

Thank you again for your business and continued support. We hope to serve you again soon.